



2023

COMPANY PROFILE



UNITESSTAR DESIGN

United World · Star Quality

www.unitedstar.com.cn

CATALOGUE

- 01 *Company Profile*
- 02 *Cooperation Mode*
- 03 *Main Product
Introduction*
- 04 *Partner*

COMPANY PROFILE

1.0



United Star Industrial group LTD. is an enterprise focusing on research and development, design, production, and sales of environmental household appliance products. The group consists of Zhongshan United Star Electrical Appliance Manufacturing CO., LTD (China high-tech enterprise), Zhongshan United Star CO., LTD., Guangzhou Link-top INT'l forwarder co., LTD. (a non-vessel carrier) and Guangzhou Unitedstar co., LTD.(foreign trade sales).

United Star has always adhered to the values of " Deliver the Best To Customer ,Be Efficient, Be Enterprising ,Be Reliable, Be Dedicated".

United Star has more than 14 years experience in home appliance product development. At present, United Star has a perfect internal structure and has passed the ISO9001 quality system of nearly 41237 square meters of plant, which includes six workshops of hardware, motor, injection molding, net cover, and final assembly. United Star has the most advanced domestic R290 mobile air conditioning production line, as well as an enthalpy difference laboratory.

We have 1133 kinds of products, among them, 82 have their property rights. We mainly produce portable air conditioner, air cooling fans, electric fans, ceiling fans, rechargeable fans, solar fans, and BLDC motors. The group has its own freight forwarding company and has more initiative in trailer and sea transportation.

United Star has six registered trademarks, more than 30 product patents, GS/CE/CB/SAA/RoHS/SASO/CCC, and other certificates. United Star has six R&D engineers, an average of 13 new products are developed every year. Our products are exported to 126 countries, we wholeheartedly for customers to provide OEM and ODM services, have cooperated with famous enterprises at home and abroad, such as French Carrefour supermarket, German Lidl supermarket, Indian Orient company, and so on. Since 2019, the sales growth rate of our own brand United Star in the global market has exceeded 250% for three consecutive years. Meanwhile, we have cooperative assembly bases in Indonesia, Tunisia, Mexico, Nigeria, and other regions.

" To be the most reliable environmental air cooling appliance provider.

UNITED WORLD · STAR QUALITY

To Be The Most Reliable Environmental
Air Cooling Appliance Provider

Mission

Committed To The Comfort And Environmental
Protection Of The Family And The Earth Environment

Values

Deliver the Best To Customer ,
Be Efficient, Be Enterprising ,Be Reliable, Be Dedicated

Vision

To be the most reliable
environmental air cooling
appliance provider;



14 YEARS
2010 2023

ENTERPRISE DEVELOPMENT PROGRESS



1.4 Social Recognition



HIGH-TECH



ISO9001



1.5 Social Recognition

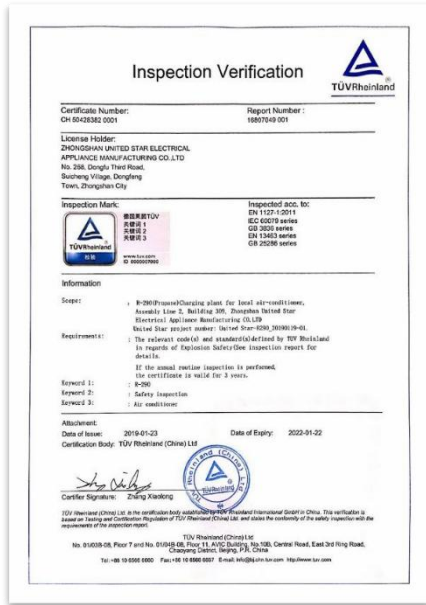

R290 Production Line Certificate



BSCI Social Responsibility



Part of Trademark Registration



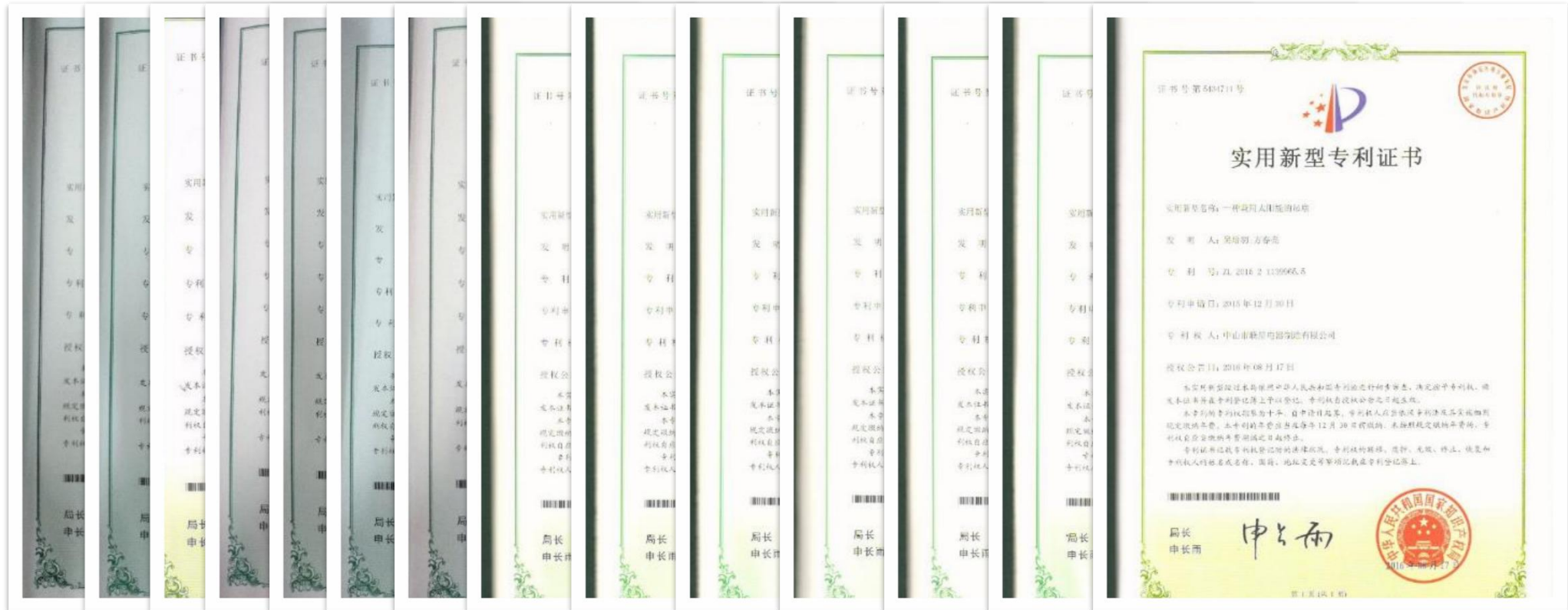

Product Patents

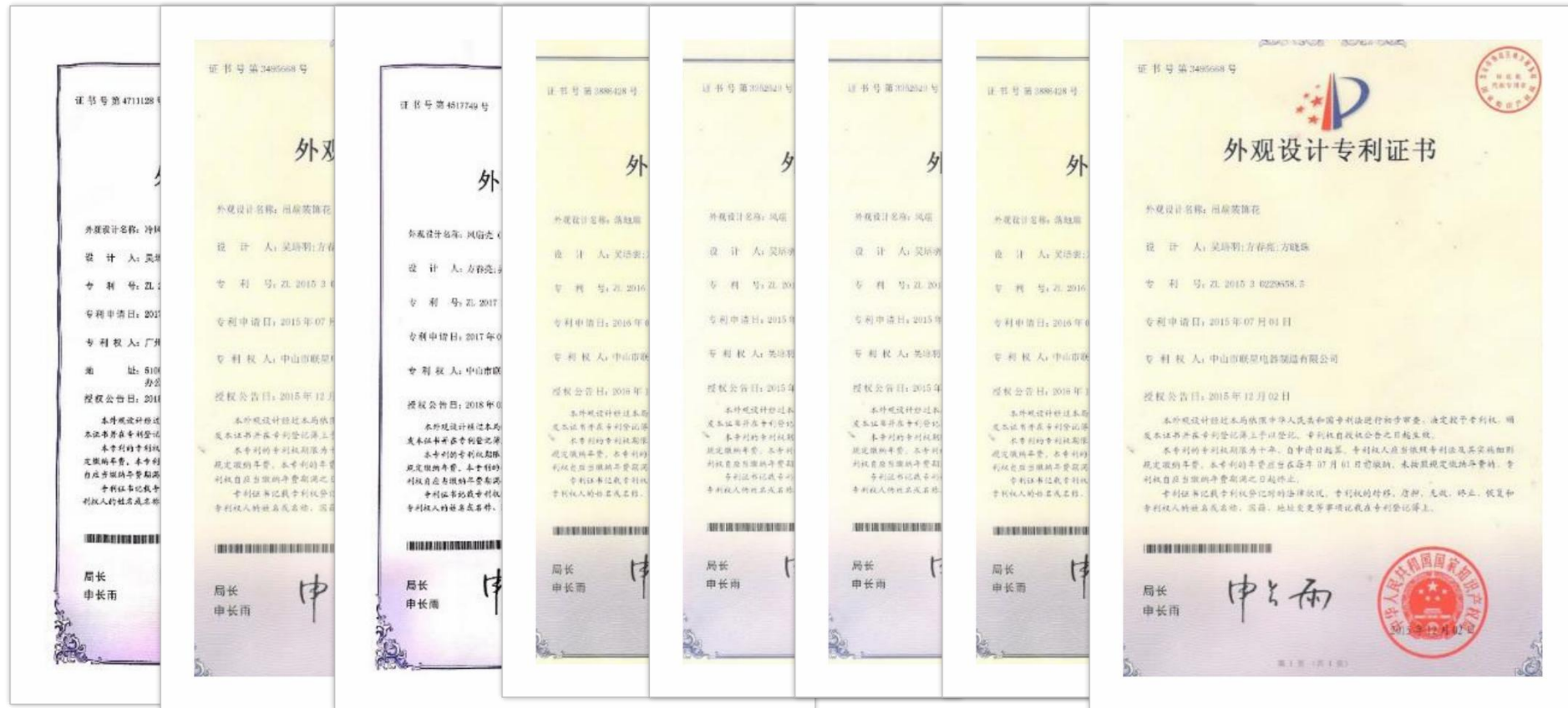

Design Patents

COOPERATION
MODE

2.0

Capacity Situation		
Name of the Product	Order Quantity	Unit
Electric fan	3,000,000	PC
Air cooler fan	100,000	PC
Air conditioner	380,000	PC

Delivery Situation		
Name of the Product	Order Quantity	Unit
Electric fan	2,640,000	PC
Air cooler fan	48,000	PC
Air conditioner	96,000	PC

2.1 OEM

Global Delivery Capability	Order Quantities	Product
Zhongshan, China	2,640,000	Fan, Portable air conditioner, Dehumidifier
Tunisia	430,000	Fan
Indonesia	1,100,000	Fan
Nigeria	600,000	Fan

2019.05-2020.05 Delivery

2.2 Our factory



Exterior View



Exterior View



Exterior View



Plant View



Plant View



Exterior View

2.2 Our factory



Plant View



Plant View



Plant View



Plant View



Plant View



Plant View



Plant View



Plant View



Plant View

2.2 Our factory



Air Conditioner Plant View



Air Conditioner Plant View



Air Conditioner Plant View



Air Conditioner Plant View



Air Conditioner Plant View



Air Conditioner Plant View



Grill Plant View



Grill Plant View



Grill Plant View

2.2 ODM Design and Development

UnitedStar⁺

1133 kinds of products in total, among them, 82 have their property rights. Mainly develop and produce portable air conditioner, air cooler, electric fan, light ceiling fan, rechargeable fan, solar fan, and BLDC motors. An average of 13 new products are developed every year.

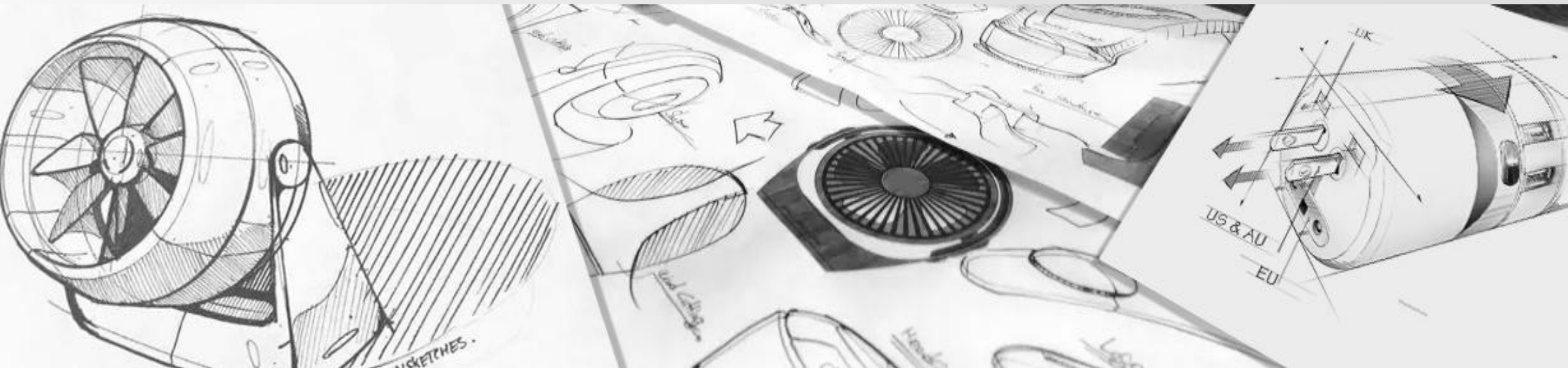

Mode: OEM, ODM, OBM

New design per year: 8-15 models

Designers: 6 person

Main design: Product appearance, product structure,

electrical structure, electrical performance, safety certificate

Tools: Auto-CAD, Pro-E, Protel, VC language



New Product Development

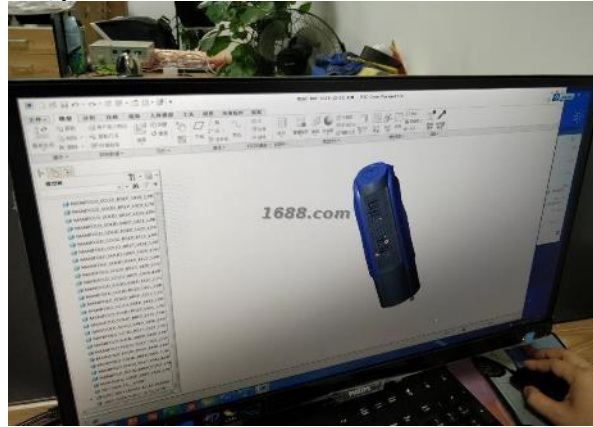

Design AIDS



Enthalpy Difference Laboratory

In 2010, a customer found us and required us to help to design a new ceiling fan.

1. We drew and got confirmed with the customer;
2. Mould fee calculated;
3. Mould tested, prepared a handmade mould for customer reference;
4. After confirmed, the mould was ready after 2 months, then we started production for the customer;
5. The customer had imported 20 containers from us in 2011.

HOT SALE

The mould was successfully developed, which is very hot-sale in local market!!! More than 100 containers of this model have been sold in three years.



2013, we have designed a motor for Indian market, as there is less electricity in the market, people prefer to use batteries and solar panels.

The power consumption of BLDC ceiling fan motor designed by us is 50% lower than that of ordinary AC ceiling fan, and it is compatible with solar energy and battery.

This product is quite popular in local market, with an annual sales of 400000 units.

HOT SALE



Design the solar ceiling fan which can use the solar panel for fan using;

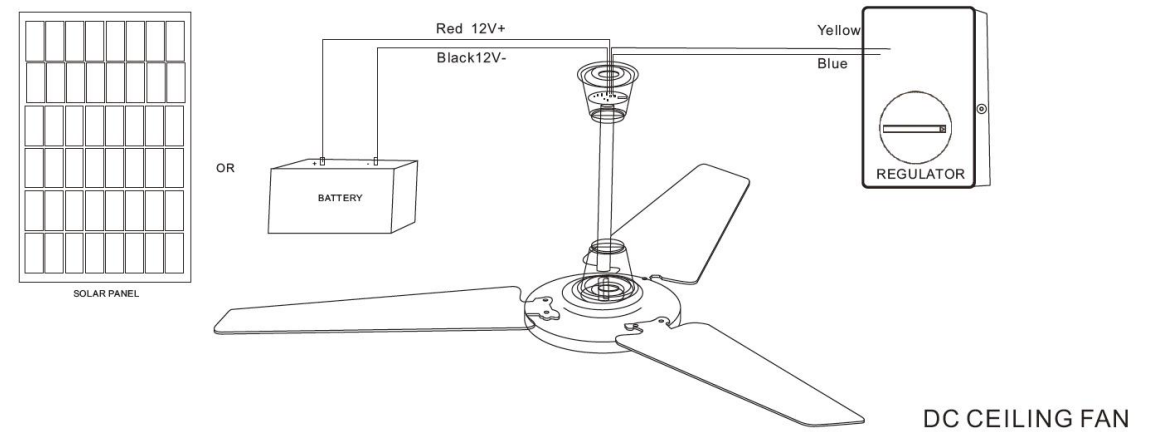

Breakthrough Portable air conditioner have Reach CLASS A++, and the noise level is 52DB.



The first company Design the Portable air conditioner into round shape design.
The first company trying to use the degradable Plastic into the Plastic



The first company Design the Portable air conditioner into OUTDOOR using



Outdoor use



Car Use



Indoor Use



Pet Use

2.2 ODM Design and Development

Water Making machine design, in order to help some people far from the city (in desert , Island) the make the water from the air.

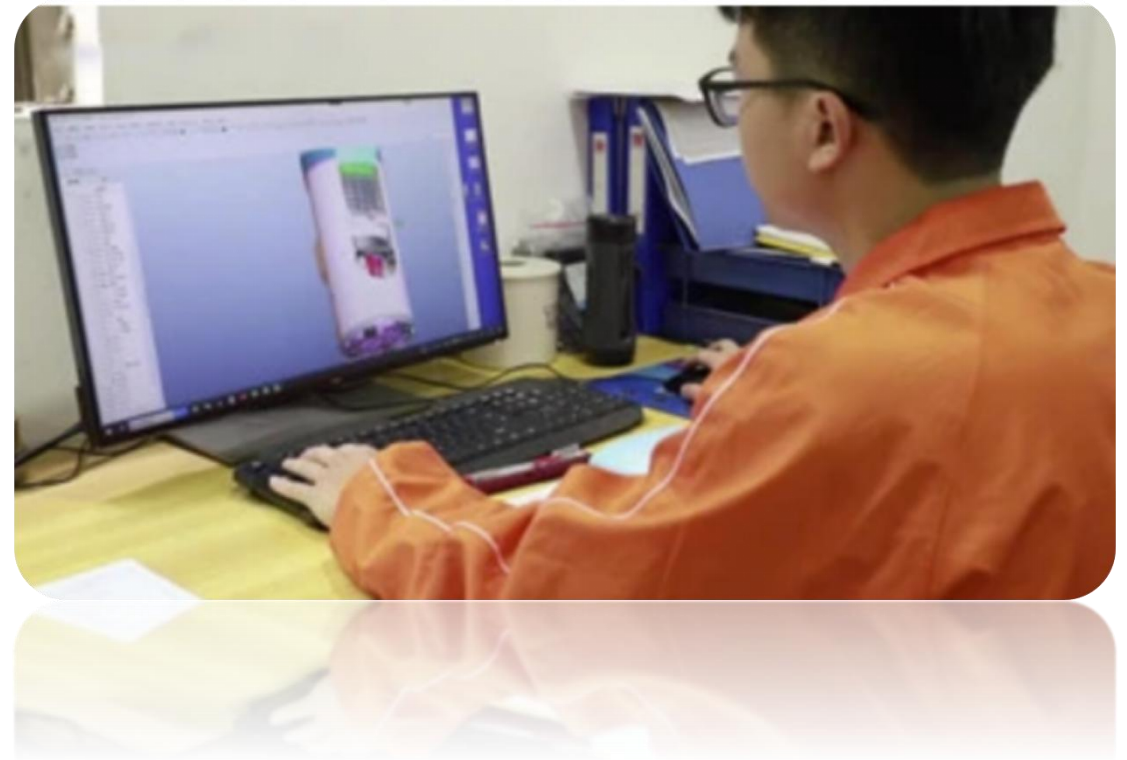

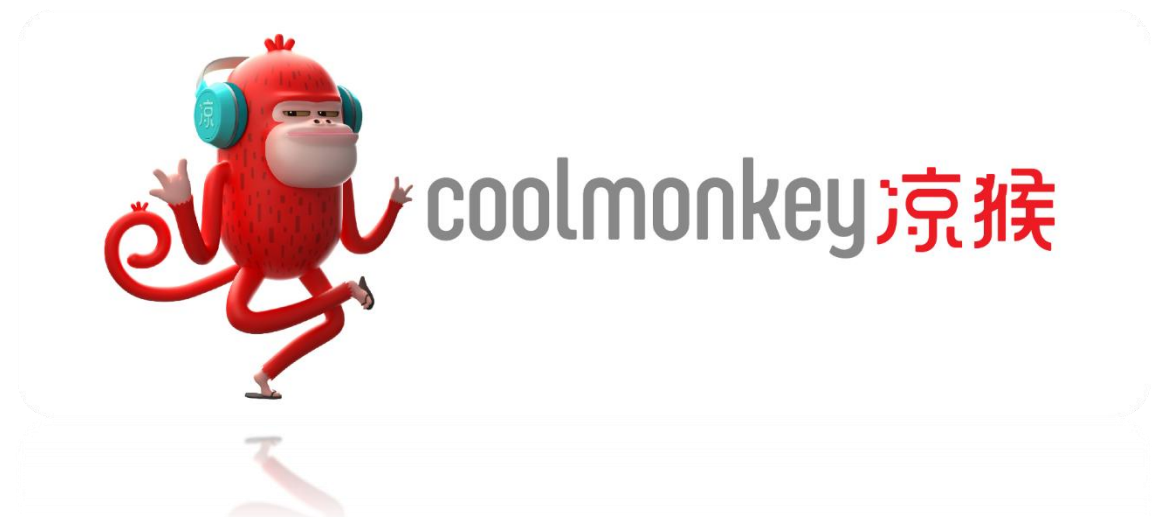

We sell our own brands in Nigeria, Ghana, South Africa, and Peru.

MAIN
PRODUCT

3.0

United World · Star Quality

UnitedStar

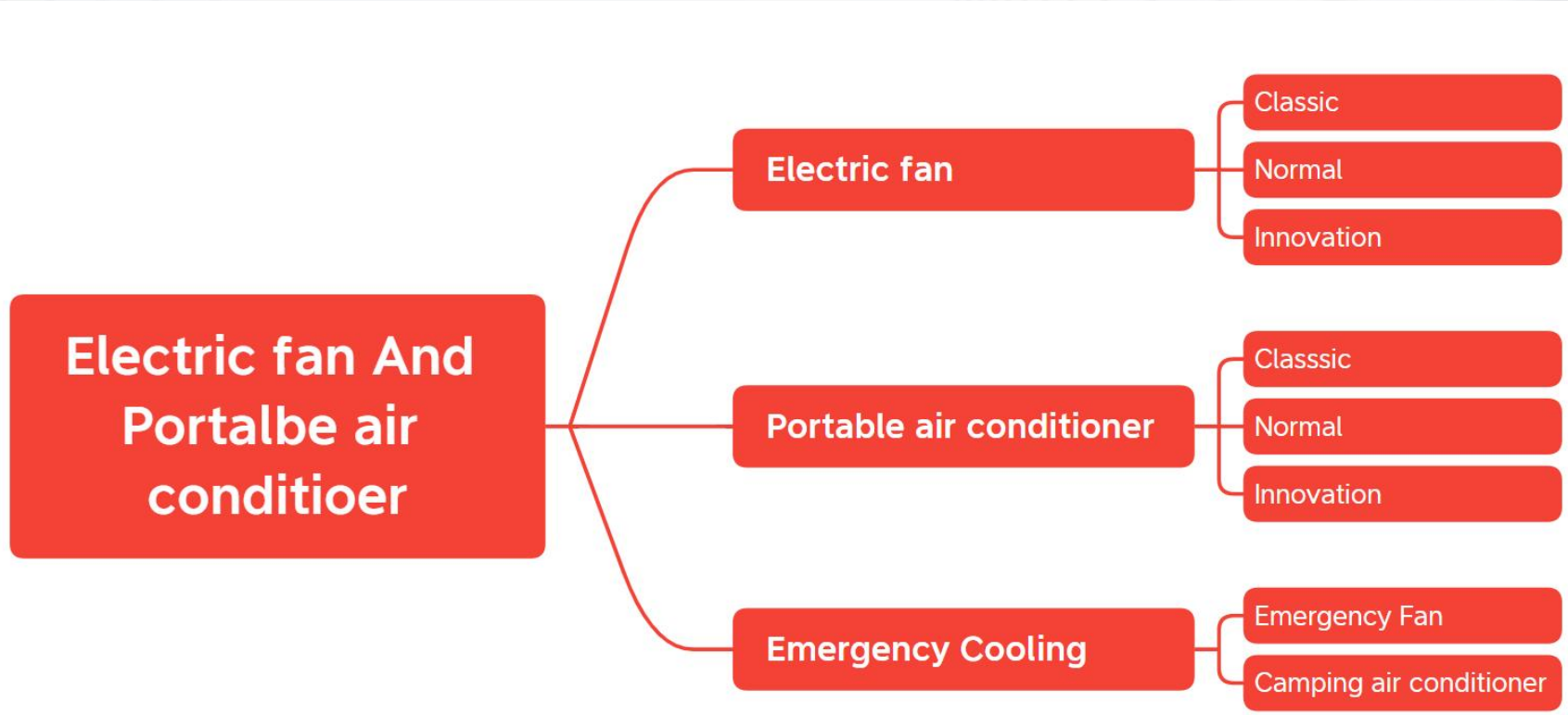

3.1 Series of Product



UnitedStar



3.1 Series of Product

UnitedStar⁺



GS CE NOMS, CB CERTIFICATION

3.1 Series of Product

UnitedStar[®]



CE

CE CERTIFICATION



USCF-145

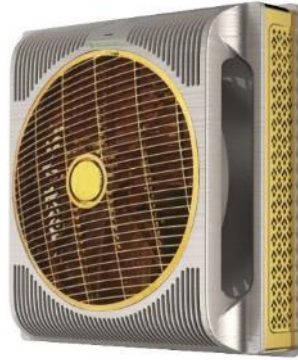

USCF-145A



USCF-145B

18-inch ceiling fan

High-end luxury design

Pure Copper ball bearing motor

The circular Air Supply

With remote control, with automatic boot function

Body material: Front ABS+ back PP

ABS Fan blade

Can be added to the aromatherapy tablets

Easy to install and disassemble



Usage scenarios:

1. Enhanced air Supply in the office
2. Student dormitory, rental housing use, easy to install and disassemble
3. Meeting venues, shops, restaurants, and other places with high indoor temperature, and air conditioning can not completely cool the room can be combined with air supply to greatly improve the refrigeration efficiency

Installation method:

Perfect and easy to install on the ceiling of 60*60
Fix it directly to the ceiling with a screw.



USCF-162

Usage scenarios:

1. Enhanced air supply in offices and conference rooms
2. Student dormitory for easy installation and disassembly
3. Meeting venues, shops, restaurants, and other places with high indoor temperature, and air conditioning can not completely cool the room can be combined with air supply to greatly improve the refrigeration efficiency

2.1 Series of Product



USCF-162

UVC light Ceiling fan

60*60 cm ceiling fan

office using

BLDC motor inside 110-240V working,

30W power

Forward and reverse (For winter and summer)

UVC light Anti-virus

2.1 Series of Product



USSF-985



Strong Wind Fan

Air Delivery (close grill):5.8m/s

Airflow:491m³/h

54DB in high speed

	6 Blade des
Air Delivery	5.8m/s
Air Flow	3427m ³ /h
Noise	54



USSF-985.mp4

MSI



+ Agregar

\$1,534.00

Hasta 12 meses sin intereses

Taurus

Ventilador industrial de piso Taurus metálico de 20" Flash

2.1 Series of Product



USSF-718

Save Feight cost Fan Design

Loading quantity 3035 PCS/40HQ

	METAL BASE	NEW DESIGN
LOADING/4 0HQ	2500PCS	3035PCS



718-2.mp4

2.1 Series of Product



USSF-718

Save Freight cost Fan Design

Loading quantity 4400 PCS/40HQ

	METAL BASE	NEW DESIGN
SKD/CKD packing	3800PCS	4400PCS



可拆风叶

2.1 Series of Product



16inch 9 BLADE and 7 BLADE

Less noise Fan Design

This 7,9 blade design will be less noise and more air delivery

2.1 Series of Product



USAF-02

Japan Style Stand Fan

BLDC MOTOR 9 SPEED

LEFT AND RIGHT OSCILLATION 60°. 90°. 120°

UP DOWN 100°

3D SHAKE HEAD

REVERSE WIND FUNCTION.



2.1 Series of Product



USAF-07

Japan Stype Fan

8 INCH TALBE FAN

10 METERS AIR DELIVER

(DC MODEL)LEFT AND RIGHT 80°, UP DOWN 90°,

3D SHAKE HEAD



USAF-07_batch.mp4

2.1 Series of Product



USAF-08

Japan Stype Fan

8INCH TABLE FAN

8 METERS AIR DELIVERY

MANUALLY UP AND DOWN 200°,



USAF-08_batch.mp4

2.1 Series of Product



USSF-010

Japan Stype Fan

16 INCH STAND FAN

4.5 METER AIR DELIVERY

55 DB IN HIGH SPEED



USSF-010.jpg

2.1 Series of Product



IDCF-012

Decorative ceiling fan with LED light

36" and 42" optional size

Foldable/transparent ABS blade

LED light with cold/neutral/warm options

BLDC motor

Remote control

Reversible wind function(for summer and winter)

6 speed regulations

Low noise

With 0.5H~8H timer

36.5 USD/PCS

2.1 Series of Product



DCF-242

Decorative ceiling fan with LED light

47" size

ABS blade

LED light with cold/neutral/warm options

BLDC motor

Remote control

Reversible wind function(for summer and winter)

6 speed regulations

Low noise

With 0.5H~8H timer

42.5USD/PCS

2.1 Series of Product



DCF-250

Decorative ceiling fan with LED light

500mm*145mm size

LED light with cold/neutral/warm options

BLDC motor

Remote control

Reversible wind function(for summer and winter)

3 speed regulations

Low noise

21.5USD/PCS

2.1 Series of Product



F0521001
Size:ø570*225mm
85~277V
Lamp:50W
Fan:20W



F0521002
Size:ø570*225mm
85~277V
Lamp:50W
Fan:20W



DCF-251

Decorative ceiling fan with LED light

570mm*225mm / 470*200mm size

LED light with cold/neutral/warm options

BLDC motor

Remote control

Reversible wind function(for summer and winter)

3 speed regulations

Low noise

36.5USD/PCS (570mm)

29.5USD/PCS(470mm)

2.1 Series of Product (NOT NEW , BUT may be good for Mexico market)



USMIF-40

Water mist fan

16 inch size

Remote control

2.5 liter water tank

For the area are desiccation

29.5USD/PCS



USCF-006

Mobile Cooler (water-cooled fan)

1500m³/H

15 liter water tank

86cm height

Full and strong air supply in the upper and lower directions and left and right directions

With a filter to effectively isolate the PM2.5 in the air

With negative ions to increase oxygen content in the air

With remote control, natural wind speed and sleep speed function to choose from



USCF-007

Mobile Cooler (water-cooled fan)

2500m³/H

30 liter water tank

124cm height

Full and strong air supply in the upper and lower directions and left and right directions

With a filter to effectively isolate the PM2.5 in the air

With negative ions to increase oxygen content in the air

With remote control, natural wind speed and sleep speed function to choose from



Portable Air Conditioner(Basic)

7000 BTU /8000 BTU

R290/ R410 refrigerant

Air conditioner, Dehumidification, Fan, Heater 4 in
1 function

Remote control

Less than 60 Db noise level





SKY-3A

Portable Air Conditioner(Luxury)

9000BTU

R290/ R410 refrigerant

Air conditioner, Dehumidification, Fan, Heater 4 in
1 function

Remote control

Less than 60 Db noise level

EER class A

TUYA WIFI function



Cool Dehumidification Speed Timer Heater Remote Refrigeration Refrigeration



SKY-5A

Portable Air Conditioner(Business)

Business Portable Air Conditioner

1. Can choose R290 refrigerant, which won't destroy the atmosphere, it's the most environmentally friendly refrigerant at present.
2. Dehumidification and refrigeration drain separation, which can avoid dehumidification when drainage into the water wheel, and circulation to the air humidification, and reduce dehumidification efficiency
3. IP24 high waterproof grade, suitable for outdoor

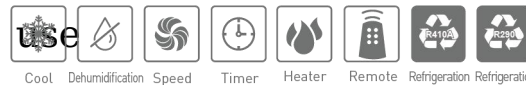

Cool Dehumidification Speed Timer Heater Remote Refrigeration Refrigeration

2.2.1 Series of Product



OAC-2A

Outdoor(Camping) Air Conditioner

5 Second cooling start

5000BTU for 15-25M² ROOM Using

Indoor and outdoor using

24hour timer/ wifi function



新品户外空

2.2.1 Series of Product



Outdoor use



Car Use



Indoor Use



Pet Use

Model	OAC-2A-09	OAC-2A-15
Voltage	230V 50Hz	
Refrigerant	R134A	
Rated Cooling Capacity	3000 BTU	5000 BTU
Cooling Power	420W	560W
EER	2.1	2.6
Dehumidifier Capacity	0.5L/H	0.7L/H
Wind Speed	High,Medium,Low	
Working Noise	≤60dB	

2.2.2 Series of Product



USDM-01

18L Dehumidifier

3L Water tank

GMCC Compressor

R290 / R135 Refrigerant



DM-01-天猫.j



DM-01.mp4

2.2.2 Series of Product



1.2 Meter Air Conditioner

22000 BTU for 35-55M² ROOM Using

Without Outdoor unit;

High air speed for quickly cooling

2.3.1 Series of Product



USDC-561

Camping fan with LED

Without Power-supply fan working 4.5-10 hours

Without Power-supply LED working 20H

2.3.1 Series of Product



USDC-563

Camping fan with LED

Without Power-supply fan working 4.5-10 hours

Without Power-supply LED working 20H

USB mobile charge



USDC-562_batch.mp4

2.3.2 Series of Product



USDC-563

Camping fan with LED

Without Power-supply fan working 4.5-10 hours

Without Power-supply LED working 20H

USB mobile charge

Can be with solar panel



USDC-465_batch.mp4

2.3.3 Series of Product



USDC-489

Camping fan with LED

Without Power-supply fan working 4.5-10 hours

Without Power-supply LED working 20H

USB mobile charge

90° 120° 180° 360° oscillation

Anti-mosquito function

Can be with solar panel



USDC-489.mp4



USDC-489.jpg

2.2.4 Series of Product



USDC-479

Solar rechargeable fan

Without Power-supply fan working 4.5-10 hours

Without Power-supply LED working 20H

USB mobile charge

LED Function

Can be with solar panel



USDC-477.mp4

2.3.5 Series of Product



Outdoor use



Car Use



Indoor Use



Pet Use

Model	OAC-2B-03
Voltage	48VDC
Refrigerant	R134A
Rated Cooling Capacity	3000 BTU
Cooling Power	420W
EER	2.1
Dehumidifier Capacity	0.5L/H
Wind Speed	High,Medium,Low
Working Noise	≤60dB

PARTNER

4.0

United World · Star Quality

UnitedStar★

taurus

Royalstar

ROYAL[®]
FANS

**PAK
FAN**
Noiseless Matchless

Walmart 

MELING 美菱

Thanks!

UNIT1005 MARITIME BUILDING NO.48, BAQI 2ND ROAD YUEXIU GUANGZHOU, CHINA

Tel:(86)20-83527484, (86)20-83527464, (86)20-83514885

QQ: 850152048 , 1127861890 WECHAT:13556009681

Email: info@unitedstar.com.cn

Website:<http://www.unitedstar.com.cn>